

Ice maker Nugget

Electronic Control Interface - ECI

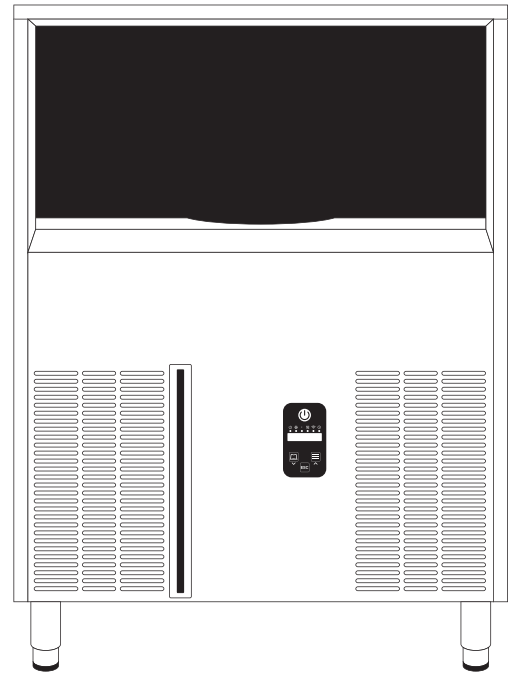

EN* User manual



Foreword

 → Read the following instructions, including the warranty terms before installing and using the appliance.

The installation, use and maintenance manual (hereinafter “Manual”) provides the user with information necessary for correct and safe use of the appliance.

The following must not be considered a long and exacting list of warnings, but rather a set of instructions suitable for improving machine performance in every respect and, above all, preventing injury to people and animals and damage to property due to improper operating procedures.

All persons involved in the transport, installation, commissioning, use, maintenance, repair, and disassembly of the appliance must consult and carefully read this manual before carrying out the various operations, in order to avoid wrong and improper actions that could compromise the appliance’s integrity or endanger people. Make sure to periodically inform the appliance user regarding safety regulations. It is also important to instruct and update personnel authorized to operate on the appliance, regarding its use and maintenance.

The Manual must be available to operators and carefully kept in the place where the appliance is used, so that it is always at hand for consultation in case of doubts or whenever required.

If, after reading this manual, there are still doubts regarding use of the appliance, do not hesitate to contact the Manufacturer or the authorized Service Center to receive prompt and precise assistance for better operation and maximum efficiency of the appliance. During all stages of appliance use, always respect the current regulations on safety, workplace hygiene, and environmental protection. It is the user’s responsibility to make sure the appliance is started and operated only in optimum conditions of safety for people, animals, and property.

IMPORTANT

1. The manufacturer declines any liability for operations carried out on the appliance without respecting the instructions given in this manual.
2. The manufacturer reserves the right to modify the appliances presented in this publication without notice.
3. No part of this manual may be reproduced.
4. This manual is available in digital format. Contact the dealer or reference Customer Care Service;
The manual must always be kept in an easily accessible place near the appliance. Appliance operators and maintenance personnel must be able to easily find and consult the manual at any time.

Contents

A	WARNINGS AND SAFETY INFORMATION	5
A.1	General information	5
A.2	Personal Protective Equipment (PPE).....	5
A.3	R290 propane ice makers.....	6
A.4	General safety.....	6
A.5	Protective devices installed on the appliance	6
A.6	Signs on the ice maker	7
A.7	Reasonably foreseeable improper use	7
A.8	Residual risks.....	7
A.9	Water connection.....	7
A.10	Electrical connection	8
A.11	Cleaning the appliance	8
A.12	Preventive maintenance	8
A.13	Spare parts and accessories	8
A.14	Information regarding use and maintenance	8
A.15	Maintenance of the appliance	8
B	WARRANTY	8
B.1	Warranty terms and exclusions	8
C	GENERAL SAFETY RULES	9
C.1	Introduction.....	9
C.2	Mechanical safety characteristics, hazards.....	9
C.3	Protective devices installed on the appliance	9
C.3.1	Guards - The appliance has:	9
C.3.2	Safety devices - The appliance has:	9
C.4	Safety signs to be placed on the appliance or near its area	9
C.5	Decommissioning	9
D	GENERAL INFORMATION	10
D.1	Introduction.....	10
D.2	Testing	10
D.3	Definitions.....	10
D.4	Machine and manufacturer's identification data.....	10
D.5	Responsibility	11
D.6	Copyright	11
D.7	Storing the manual	11
D.8	Recipients of the manual	11
E	NORMAL APPLIANCE USE	11
E.1	Characteristics of personnel enabled to operate on the appliance.....	11
E.2	Basic requirements for appliance use	11
F	Technical data	12
G	Description, characteristics and intended use.....	12
G.1	Introduction to the machine.....	12
H	INSTALLATION	13
H.1	Storage	13
H.2	Machine handling	13
H.3	Unpacking and disposal	13
H.4	Positioning	14
H.5	Water connection.....	15
H.6	Electrical connection	16
H.7	Safety devices installed	16
H.8	Positioning the modular ice maker	16
H.8.1	Installing the ice level probe	17
H.8.2	Connecting the modular ice maker	17
H.8.3	Description of the modular ice maker	17
H.8.4	Connecting the modular ice maker	18
I	Description of controls.....	19
I.1	Color codes of the ON/OFF button	19
J	START-UP	20
J.1	Start-up.....	20
J.2	Preliminary checks and interior cleaning	20
J.3	First switch-on	21
J.4	Turning off and turning on afterwards.....	22
K	ADJUSTMENTS	22
K.1	Adjustments.....	22
K.2	User menu and clock settings	22
K.3	User and service menu	22

L	CARE AND MAINTENANCE.....	23
	L.1 Care and maintenance.....	23
	L.2 Cleaning the tub	23
	L.3 Cleaning the external parts.....	23
	L.4 Cleaning the air filter.....	23
	L.5 Sanitization	23
	L.6 Extraordinary maintenance.....	24
M	MAINTENANCE AND DISPOSAL TABLE.....	24
	M.1 Maintenance and disposal.....	24
	M.2 When not in use.....	24
	M.3 Appliance disposal	24
N	WARNING	25
	N.1 Display warnings.....	25
O	ALARMS.....	25
	O.1 Display alarms	25
	O.2 Table of alarms.....	26
	O.3 Power blackout.....	26

A WARNINGS AND SAFETY INFORMATION

A.1 General information

To ensure safe use of the appliance and a proper understanding of the manual, it is necessary to be familiar with the terms and typographical conventions used in the documentation. The following symbols are used in the manual to indicate and identify the various types of hazards:

 **WARNING**
Danger for the health and safety of operators.

 **WARNING**
Electrical shock hazard - dangerous voltage.

 **ATTENTION**
Risk of damage to the appliance or the product.

 **IMPORTANT**
Important instructions or information on the product.

 Equipotentiality.





 Read all instructions before using the appliance.

 Clarifications and explanations.

- Only specialized personnel are authorized to operate on the appliance.
- This appliance is not intended for use by persons (including children) with reduced physical, sensory or mental capabilities, or lack of experience and knowledge, unless they have been given supervision or instruction concerning use of the appliance by a person responsible for their safety.
- Do not let children play with the appliance.
- Keep all packaging and detergents away from children.
- Cleaning and maintenance must not be done by children without supervision.
- For your safety, do not store or use gasoline or other flammable materials, in liquid or gaseous state, near this or any other appliance.
- Do not store explosive substances, such as pressurized containers with flammable propellant, in this appliance.
- Refer to the data given on the appliance's data plate for relations with the Manufacturer (e.g. when ordering spare parts, etc.).
- When scrapping the appliance, the CE marking must be destroyed.
- Store these instructions carefully for further consultation by various operators.

A.2 Personal Protective Equipment (PPE)

Summary table of the Personal Protective Equipment (PPE) to be used during the various stages of the appliance's service life.

Stage	Protective garments 	Safety footwear 	Gloves 	Goggles 	Safety helmet 
Transport	-	●	○	-	○
Handling	●	●	○	-	-
Unpacking	○	●	○	-	-
Installation	○	●	● ¹	-	-
Normal use	●	●	● ²	○	-
Adjustments	○	●	-	-	-
Routine cleaning	○	●	● ¹⁻³	○	-
Extraordinary cleaning	○	●	● ¹⁻³	○	-
Maintenance	○	●	○	-	-
Dismantling	○	●	○	○	-
Scrapping	○	●	○	○	-
Legend:					
●	PPE REQUIRED				
○	PPE AVAILABLE OR TO BE USED IF NECESSARY				
-	PPE NOT REQUIRED				

1. Wear cut-resistant gloves during these operations. Failure to use personal protective equipment by operators, specialized personnel or other users of the appliance can involve exposure to damage to health (depending on the model).
2. During these operations, gloves must be heatproof and suitable for contact with water and the substances used (refer to the safety data sheet of the substances used for information regarding the required PPE). Failure to use personal protective equipment by operators, specialized personnel or users of the appliance can involve exposure to chemical risk and cause possible damage to health (depending on the model).
3. During these operations, gloves must be suitable for contact with the chemical substances used (refer to the safety data sheet of the substances used for information regarding the required PPE). Failure to use personal protective equipment by operators, specialized personnel or users of the appliance can involve exposure to chemical risk and cause possible damage to health (depending on the model).

A.3 R290 propane ice makers



- This ice maker contains R-290 propane. The quantity differs depending on the manufacturer model, and is indicated in the data plate.
- Propane is a natural refrigerant with a GWP (Global Warming Potential) of 3. This means it has minimal impact on the environment.
- R-290 gas is a flammable gas (ISO 817 standard). The installer is required to check any fire regulations at the place of installation.
- R-290 gas has a higher molecular weight than air. In the event of leaks from the appliance, the gas will tend to accumulate downwards; avoid enclosing the equipment in low areas.
- Keep the appliance at least 3m away from any sources of fire, combustible or explosive materials. Ensure that there is always good air circulation in the place where the appliance is installed.

A.4 General safety

- The appliances are provided with electrical and/or mechanical safety devices for protecting workers and the appliance itself.
- Never operate the appliance after removing, modifying or tampering with the guards, protections or safety devices.
- Do not make modifications to the parts supplied with the appliance.
- Several illustrations in the manual show the appliance, or parts of it, without guards or with guards removed. This is purely for explanatory purposes. Do not use the appliance without the guards or with the protective devices deactivated.

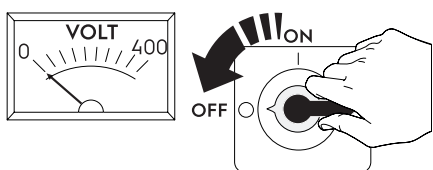

Disconnect the appliance from the power supply before carrying out any installation, assembly, cleaning or maintenance procedure.

- Do not remove, tamper with, or make illegible the CE marking, the safety, danger, and instruction signs and labels on the appliance.
- The A-weighted emission sound pressure level does not exceed 70 dB(A).
- The following operations must be carried out by specialized authorized personnel or Customer Care Service provided with all the appropriate personal protective equipment (A.2 Personal protective equipment), tools, utensils and ancillary means, who can ask the manufacturer to supply a servicing manual:
 - Installation and assembly
 - Positioning
 - Electrical connections
 - Cleaning, repair and extraordinary maintenance of the machine
 - Appliance disposal
 - Work on electrical appliances

A.5 Protective devices installed on the appliance



Guards - The appliance has:

- Fixed guards (e.g. casings, covers, side panels, etc.), fixed to the appliance and/or frame with screws or quick-release connectors that can only be removed or opened with tools. Therefore the user must not remove or tamper with such devices. The Manufacturer declines any liability for damage due to tampering or failure to use these guards.
- Panels or doors to access the appliance's electrical equipment, made from hinged panels that can be opened with tools. The panel or the door must not be opened when the appliance is connected to the power supply.

Safety devices - The appliance has:

- Safety probe monitoring the refrigeration system temperature and stopping operation if abnormal temperatures are reached. In the event of a fault in the probe, operation of the ice maker is immediately stopped.
- Water level micro-switch. There is a micro-switch that checks for water in the tank and stops operation of the ice maker if there is no water.
- Motor thermal protection. The motor for extracting ice is protected by a thermal protection that stops the motor in case of overload due to excessive ice.
- Chute micro-switch. Modular ice makers feature a micro-switch that stops operation if the ice outlet chute becomes clogged with ice.

A.6 Signs on the ice maker

Danger	Meaning
	R-290 PROPANE Risk of fire in the event of GAS leaks
	Do not have open flames near the appliance
	read and understand the contents of this manual before switching on the appliance

A.7 Reasonably foreseeable improper use

Improper use is any use different from that specified in this manual. During appliance operation, other types of work or activities deemed improper and that in general can involve risks for the safety of operators and damage to the appliance are not allowed. Reasonably foreseeable improper use includes:

- Lack of appliance maintenance, cleaning and periodical checks;
- Structural changes or modifications to the operating logic;
- Tampering with the guards or safety devices;
- Failure to use personal protective equipment by operators, specialized personnel and maintenance personnel;
- Failure to use suitable accessories (e.g. use of unsuitable equipment or ladders);
- Keeping combustible or flammable materials, or in any case materials not compatible with or pertinent to the work, near the appliance;
- Incorrect appliance installation;
- Placing in the appliance objects incompatible with its function or that can damage the appliance itself, injure people or pollute the environment;
- Climbing on the appliance;
- Non-compliance with the requirements for correct appliance use;
- Other actions creating risks that cannot be eliminated by the Manufacturer.

A.8 Residual risks

The appliance has several risks that were not completely eliminated from a design standpoint or with the installation of adequate protection devices. Nevertheless, through this manual, the Manufacturer has taken steps to inform operators of such risks, carefully indicating the personal protective equipment to be used by the operators themselves. In order to reduce these risks, provide for enough space while installing the unit.

To preserve these conditions, the areas around the appliance must always be:

1. Kept free of obstacles (e.g. ladders, tools, containers, boxes, etc.);
2. Clean and dry;
3. Well lit.

For the Customer's complete information, the residual risks remaining on the appliance are indicated below: such actions are deemed improper and therefore strictly forbidden.

Residual risk	Description of hazardous situation
Slipping or falling	The operator can slip due to water, liquids, or dirt on the floor.
Stab wounds	The operator deliberately or unintentionally touches some components with sharp edges while cleaning the appliance without using protective gloves.
Ice burns	The operator touches the ice in the tank, whether intentionally or not
Electric shock	Contact with some parts during maintenance operations carried out with the electrical panel powered.
Falling from above	The operator intervenes on the appliance using unsuitable systems to access the upper part (e.g. rung ladders, or climbs on it).
Crushing or injury	Specialized personnel may not correctly secure the control panel when accessing the technical compartment.
Crushing or shearing	Possible risk of injury to upper limbs during the hood closing operation.
Tipping of loads	Use of lift equipment or accessories that are unsuitable or with an unbalanced load when handling the appliance or the packaging containing it.
Chemical substances	Contact with chemical substances (e.g. scale remover, etc.) without taking adequate safety precautions. Therefore always refer to the safety data sheets and labels on the products used.

A.9 Water connection

- The operating water pressure (minimum and maximum) must be between: 1 bar [100 kPa] and 5 bar [500 kPa];
- The operating water temperature (minimum and maximum) must be between: +10°C and +32°C;
- The operating water hardness must be less than 20°f (11.2°d);
- Check that there are no visible water leaks during and after the first time using the machine.

A.10 Electrical connection

- If the power cable is damaged it must be replaced by the Customer Care Service or in any case by specialized personnel, in order to prevent any risk.

A.11 Cleaning the appliance

- Do not touch the appliance with wet hands or feet or when barefoot.
- Use a ladder with suitable protection for work on equipment with high accessibility.
- Put the appliance in safe conditions before starting any cleaning operation.
- Respect the requirements for the various routine and extraordinary maintenance operations. Non-compliance with the instructions can create risks for personnel.
- Do not spray water or use water jets, steam cleaners or high pressure cleaners.

A.12 Preventive maintenance

To ensure the safety and performance of the appliance, we recommend having authorized engineers perform maintenance operations every 12 months, in compliance with the service manuals. Please contact your local service center for further details.

A.13 Spare parts and accessories

Use only original accessories and/or spare parts. Failure to use original accessories and/or spare parts will invalidate the original manufacturer warranty and may render the appliance not compliant with safety standards.

A.14 Information regarding use and maintenance

- Risks mainly of a mechanical, thermal and electrical nature exist in the appliance. Where possible, the risks have been neutralized:
 - directly, by means of adequate design solutions;
 - or indirectly by using guards, protections and safety devices.
- Any anomalous situations are signaled on the control panel display.
- During maintenance several risks remain, as these could not be eliminated, and must be neutralized by adopting specific measures and precautions.
- Do not carry out any checking, cleaning, repair or maintenance operations on moving parts. Workers must be informed of this prohibition by means of clearly visible signs.
- Periodically, make sure to check that all safety devices are working correctly, and to check the insulation of electrical cables, which must be replaced if damaged.

In case of a significant anomaly (e.g. short circuits, wires coming out of the terminal block, motor breakdowns, worn electrical cable sheathing, etc.) the operator for normal appliance use must:

- Immediately deactivate the appliance;
- Where applicable, close the appliance water supply by shutting off the water.

A.15 Maintenance of the appliance

- The inspection and maintenance intervals depend on the actual appliance operating conditions and ambient conditions (presence of dust, damp, etc.), therefore precise time intervals cannot be given. In any case, careful and periodical appliance maintenance is advisable in order to minimize service interruptions.
- It is advisable to stipulate a scheduled preventive maintenance contract with the Customer Care Service.
- Put the appliance in safe conditions before starting any maintenance operation.
- To guarantee appliance efficiency and correct operation, periodical maintenance must be carried out according to the instructions given in this manual.

B WARRANTY

B.1 Warranty terms and exclusions

If the purchase of this product includes warranty coverage, warranty is provided in line with local regulations and subject to the product being installed and used for the purposes as designed, and as described within the appropriate equipment documentation. The warranty is applicable if the customer has used only original spare parts and has performed maintenance in accordance with the maintenance documentation made available in paper or electronic form. It is strongly recommended to use cleaning, rinse and descaling agents approved by the manufacturer to obtain optimal results and maintain product efficiency over time.

The manufacturer's warranty does not cover:

- Service trip costs to deliver and pick up the product;
- Installation;
- Training on how to use/operate the appliance;
- Replacement (and/or supply) of damaged wear and tear parts unless resulting from defects in materials or workmanship reported within one (1) week from the failure;
- Correction of external wiring;
- Correction of unauthorized repairs as well as any damages, failures, and inefficiencies caused by and/or resulting from:
 - Insufficient and/or abnormal capacity of the electrical systems (current/voltage/frequency, including spikes and/or outages);

- Inadequate or interrupted water supply, steam, air, gas (including impurities and/or other that does not comply with the technical requirements for each appliance);
- Plumbing parts, components or consumable cleaning products that are not approved by the manufacturer;
- Customer's negligence, misuse, abuse and/or non-compliance with the use and care instructions detailed within the appropriate appliance documentation;
- Improper or poor: installation, repair, maintenance (including tampering, modifications and repairs carried out by unauthorized third parties) and modification of safety systems;
- Use of non-original components (e.g. consumables, wear and tear, or spare parts);
- Ambient conditions provoking thermal (e.g. overheating/freezing) or chemical (e.g. corrosion/oxidation) stress;
- Foreign objects placed in or connected to the product;
- Accidents or force majeure;
- Transportation and handling, including scratches, dents, chips, and/or other damage to the finish of the product, unless such damage results from defects in materials or workmanship and is reported within one (1) week of delivery unless otherwise agreed;
- Product with original serial numbers that have been removed, altered or cannot be readily determined;
- Replacement of light bulbs, filters or any consumable parts;
- Any accessories and software not approved or specified by the manufacturer.

The warranty will be void and the manufacturer shall have no liability related thereto in case of any modification of the product or related hardware/software/programming.

Warranty does not include scheduled maintenance activities (including the parts required for it) or the supply of cleaning agents unless specifically covered within any local agreement, subject to local terms and conditions.

C GENERAL SAFETY RULES

C.1 Introduction

The machines are provided with electrical and/or mechanical safety devices for protecting workers and the machine itself.

C.2 Mechanical safety characteristics, hazards

The machine does not have sharp edges or protruding parts. The guards for the moving and live parts are fixed to the cabinet with screws, to prevent accidental access.

C.3 Protective devices installed on the appliance





C.3.1 Guards - The appliance has:

- Fixed guards (e.g. casings, covers, side panels, etc.), fixed to the appliance and/or frame with screws or quick-release connectors that can only be removed or opened with tools. Therefore the user must not remove or tamper with such devices. The Manufacturer declines any liability for damage due to tampering or failure to use these guards.

C.3.2 Safety devices - The appliance has:

- Safety probe monitoring the refrigeration system temperature and stopping operation if abnormal temperatures are reached. In the event of a fault in the probe, operation of the ice maker is immediately stopped.

C.4 Safety signs to be placed on the appliance or near its area

Danger	Meaning
	Slip hazard
	R-290 PROPANE Risk of fire in the event of GAS leaks
	Electrical shock hazard (shown on electrical parts with indication of voltage)
	Do not have open flames near the appliance

C.5 Decommissioning

When the appliance is no longer to be used, make it unusable by removing the mains power supply wiring.

D GENERAL INFORMATION

D.1 Introduction

This manual contains information relevant to various appliances. The product images in this guide are only by way of example. The drawings and diagrams given in the manual are not in scale. They supplement the written information with an outline, but are not intended to be a detailed representation of the appliance supplied. The numerical values given on the appliance installation diagrams refer to measurements in millimeters and/or inches.

D.2 Testing

Our appliances have been designed and optimized, with laboratory testing, in order to obtain high performance and efficiency. The appliance is shipped ready for use. Passing of the tests (visual inspection - electrical test - functional test) is guaranteed and certified by the specific enclosures.

D.3 Definitions

Listed below are the definitions of the main terms used in the manual. It is advisable to read them carefully before use.

Operator	Appliance installation, adjustment, use, maintenance, cleaning, repair, and transport personnel.
Manufacturer	Manufacturing company or any other service center authorized by the manufacturer.
Operators for normal appliance use	An operator who has been informed, instructed and trained regarding the tasks and hazards involved in normal appliance use.
Customer Care Service or specialized personnel	An operator instructed/trained by the Manufacturer and who, based on his professional and specific training, experience and knowledge of accident-prevention regulations, is able to appraise the interventions to be carried out on the appliance and recognize and prevent any risks. His professionalism covers the mechanical, electrotechnical and electronics fields, etc.
Danger	A source of possible injury or harm to health.
Hazardous situation	Any situation where an operator is exposed to one or more hazards.
Risk	A combination of probabilities and risks of injury or harm to health in a hazardous situation.
Protection devices	Safety measures consisting of the use of specific technical means (guards and safety devices) for protecting operators against dangers.
Guard	An element of an appliance used in a specific way to provide protection by means of a physical barrier.
Safety device	A device (other than a guard) that eliminates or reduces the risk; it can be used alone or in conjunction with a guard.
Customer	The person who purchased the appliance and/or who manages and uses it (e.g. company, entrepreneur, firm).
Electric shock	An accidental discharge of electric current on a human body.
Emergency stop device	A group of components intended for the emergency stop function; the device is activated with a single action and prevents or reduces damage to persons/appliances/property/animals.

D.4 Machine and manufacturer's identification data

A reproduction of the marking or data plate on the machine is given below:

MODEL	XXXX	MODEL	Machine name			
TYPE	XXXX	230-240 V ~ 50 Hz	TYPE	Machine type		
CODE	XXXX - XXXX	I.max XXX A	CODE	Machine code		
S/N	YYYYYYYY	ARTICLE	POWER XXX W	S/N	Machine serial number	
REFRIGERANT R290	g. XXX	CL.T IPX2	REFRIGERANT R290	g. XXX	230V ~ 50 Hz	Power supply
Electronic code	XXXX	PW: XXXX	Electronic code	XXXX	I.max	Current absorbed
		PW	Password to access parameters			
		REFRIGERANT R290 g. XXX	Propane refrigerant and quantity inside cooling circuit			

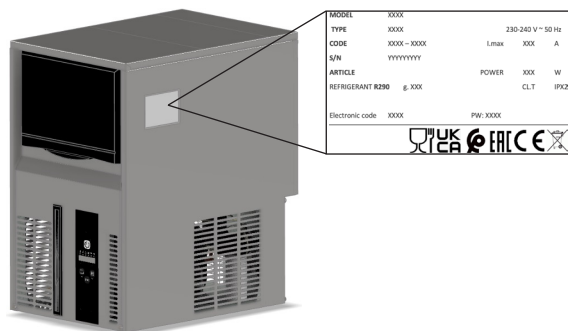

The data plate is located on the right side panel of the appliance.



WARNING

Do not remove, tamper with or make the machine's marking illegible.

IMPORTANT

When scrapping the machine, the marking must be destroyed.

NOTE!

Refer to the data given on the machine marking for relations with the Manufacturer (e.g. when ordering spare parts, etc.).

D.5 Responsibility

The Manufacturer declines any liability for damage and malfunctioning caused by:

- Non-compliance with the instructions contained in this manual;
- Repairs not carried out in a workmanlike fashion, and replacements with parts different from those specified in the spare parts catalog (the fitting and use of non-original spare parts and accessories can negatively affect appliance operation and invalidates the original manufacturer warranty);
- Operations carried out by non-specialized personnel;
- Unauthorized modifications or interventions;
- Missing, lack of, or inadequate maintenance;
- Improper appliance use;
- Unforeseeable extraordinary events;
- Use of the appliance by uninformed and/or untrained personnel;
- Non-application of the current provisions in the country of use, concerning safety, hygiene and health in the workplace.

The Manufacturer declines any liability for damage caused by arbitrary modifications and conversions carried out by the user or the Customer. The employer, workplace manager or service technician are responsible for identifying and choosing adequate and suitable personal protective equipment to be worn by operators, in compliance with the regulations in force in the country of use.

The Manufacturer declines any liability for possible inaccuracies contained in the manual, if due to printing or translation errors. Any supplements to the installation, use, and maintenance manual the Customer receives from the manufacturer will form an integral part of the manual and therefore must be kept together with it.

D.6 Copyright

This manual is intended solely for consultation by the operator and can only be given to third parties with the permission of the manufacturer.

D.7 Storing the manual

The manual must be carefully kept for the entire life of the appliance, until scrapping. This manual must stay with the appliance in case of transfer, sale, hire, granting of use, or leasing.

D.8 Recipients of the manual

This manual is intended for:

- The employer of appliance users and the workplace manager;
- Operators for normal appliance use;
- Specialized personnel - Customer Care Service (see service manual).

E NORMAL APPLIANCE USE

E.1 Characteristics of personnel enabled to operate on the appliance

The Customer must make sure the personnel for normal appliance use are adequately trained and skilled in their duties.

The operator must:

- Read and understand the manual;
- Receive adequate training and instruction for their duties in order to operate safely;
- Receive specific training for correct appliance use.



IMPORTANT

The Customer must make sure his personnel have understood the instructions received and in particular those regarding workplace hygiene and safety in use of the appliance.

E.2 Basic requirements for appliance use

- Knowledge of the technology and specific experience in operating the appliance.
- Adequate general basic education and technical knowledge for reading and understanding the contents of the manual, the capacity for a correct interpretation of the drawings, signs, and pictograms.
- Sufficient technical knowledge for safely performing his duties as specified in the manual.
- Knowledge of the regulations on workplace hygiene and safety.

F TECHNICAL DATA

Power supply voltage convertible to	V	Please refer to the data plate
Frequency	Hz	Please refer to the data plate
Power	kW	Please refer to the data plate
Power cable		H05VV-F
Supply water pressure	bar [kPa]	1 ÷ 5 bar [100 ÷ 500 kPa]
Supply water temperature	°C	10 ÷ 32
Rinse cycle water consumption	L.	See data sheet referring to the model concerned
Type of refrigerant		R290 (Propane)
Qty refrigerant	g.	Please refer to the data plate
Supply water hardness Connect only to drinking water supply	°f/°d	Max 20°f (11.2°d)
Legal noise level Leq	dB[A]	<70db
Protection rating	IP	Please refer to the data plate

NOTE! - For location of the data plate, please refer to section D.4 Machine and manufacturer's identification data.

G DESCRIPTION, CHARACTERISTICS AND INTENDED USE

G.1 Introduction to the machine

The machine is only intended for the use for which it was designed, i.e. for the production of ice for food use inside buildings such as restaurants, canteens, bars, restaurant kitchens and the like, clean and dust-free with adequate air exchange. Any other use, without specific permission or failure to follow the indications included in this manual, will void the warranty. **Installation outdoors is prohibited.**

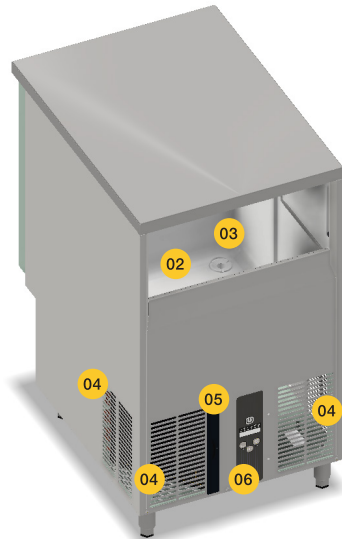
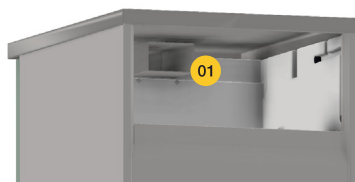

01	Ice outlet chute
02	Ice bin
03	Draining
04	Air vents
05	Air filter (air-cooled versions only)
06	Control panel

H INSTALLATION

During installation, connection and starting, strictly observe the following instructions.

- ! *The ice maker must be installed by specialized personnel, in compliance with the safety regulations in force in the place of use, and following the instructions given below. Always wear personal protective equipment to carry out this type of operation.*
- i *Failure to follow these instructions will void the manufacturer's warranty on functional performance and/or damage the machine.*
- i *If your ice maker presents any damage upon removal of the packaging, contact the dealer prior to using it.*

H.1 Storage

Before installation, the machine can be stored (carefully packed) in a sheltered place away from humidity and dust, at temperatures between 5°C and 40°C.

At the initial installation or after long periods of inactivity, it is advisable to manually rotate the pump impeller to release it from possible sticking.

H.2 Machine handling

- ! The machine must be handled by qualified personnel who have adequate experience and training regarding:
 - Applicable safety regulations.
 - The ability to identify dangerous situations and adopt the appropriate behavior.
 - The weight of the machine is given in the packaging and its technical sheet
 - The packed machine must be unloaded and transported with a forklift truck, making sure to engage the forks in the pallet frontally.
 - After unpacking the machine, transport it using a pallet truck (suitable to the weight to be lifted, see net weight specified in the data table), inserting the forks into the pallet.
 - Lodge a piece of cardboard between the pallet truck and the machine in order to avoid damaging the machine.
 - Do not lift the machine too high from the ground during transport and make sure the route is flat and free of any obstructions. Before moving the machine, check the size of passage through the doors and the space for handling operations.

- i **IMPORTANT**
Avoid transporting the ice maker on its side. If it must be transported on its side due to space issues, keep it in its final and permanent position for at least 12 (twelve) hours before putting it into operation.



H.3 Unpacking and disposal

Remove the cardboard packaging and wooden pallet. Before positioning and starting the machine, check its conditions.

- i **IMPORTANT**
All packing materials should be disposed of in conformity with the regulations in force in the country where the appliance is to be used. In any case, nothing must be dispersed into the environment.

H.4 Positioning

The ice maker must be placed in a professional and not a domestic environment equipped with suitable floor drains. Check that the floor of the installation site is level and capable of supporting the weight of the machine filled with water and the bin full of ice cubes (for the capacities of the water tank and bin, please refer to the technical data sheet downloadable from the website).

Do not install the machine in outdoor, dusty environments, or place it in areas where it can be reached by water jets.

Do not place the machine in places exposed to direct sunlight, in rooms with temperatures above 43°C or below 10°C, near heat sources and places with poor air exchange.

The machine should be positioned so that it is easily accessible by qualified maintenance personnel. The installer is responsible for checking any fire prevention requirements.

After unpacking, remove any protective film from the steel walls:

- Install the supplied feet (feet may vary depending on model).

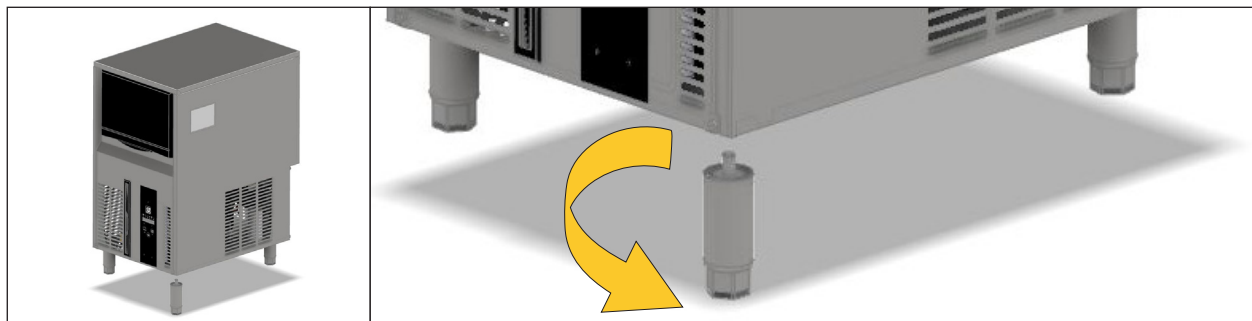

- Position the ice maker taking care to adjust the feet so that the appliance is leveled properly.



- If the machine is recessed, leave sufficient space between the wall of the ice maker and the wall of the cabinet to allow proper air circulation.
- In air-cooled machines, in order for the ice maker to function properly, it is essential to keep at least 25mm of space between the machine walls and the cabinet walls, between the top of the machine and the top of the cabinet. Adjust the feet to ensure airflow at the base of the ice maker.
- Also keep at least 100mm clearance from the back wall.

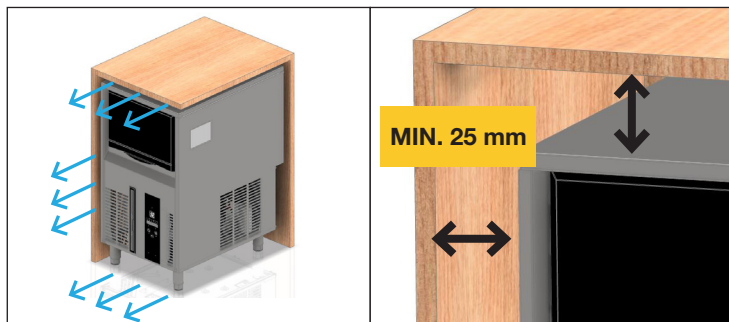

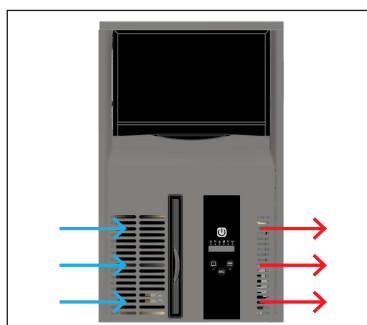

- Position the ice maker in such a way as to ensure proper airflow through the front grills at all times. Do not place objects in front of the machine that may obstruct the grill.
- When placing the appliance, be careful not to crush or trap the pipes and power cable.



 In air-cooled machines, failure to comply with the above measures may lead to malfunction of the ice maker resulting in tripping of the protective devices.

H.5 Water connection



  *The connections must be carried out by qualified personnel in compliance with the laws in force in the place of installation.*

In air-cooled versions, the machine is equipped with only one water inlet hose (already installed) that will have to be connected to the water mains to supply the ice production tub.

- The hose is marked with the green “*DRINKING WATER CONNECTION*” label and must be connected only to the cold potable water mains.

In water-cooled versions, there are 2 inlet hoses already installed.

- The hose marked with the green “*DRINKING WATER CONNECTION*” label must be connected only to the cold potable water mains as it supplies the ice production tub.
- The hose marked with the blue “*COOLING WATER CONNECTION*” label must be connected only to the cold water mains as it supplies the cooling condenser (maximum temperature allowed 32°C/90°F).

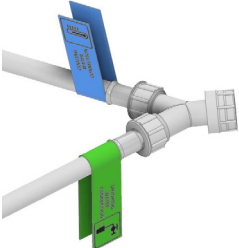
	<p>Inlet hose connection to cold potable water mains. Water for ice production.</p>
	<p>Inlet hose connection to cold water mains. Cooling circuit water intended for drainage.</p>
	<p>It is possible to join the 2 inlet hoses using the T-piece pipe fitting supplied with the ice maker.</p>

Make sure that:

- The water temperature is between +10°C (50°F) and +32°C (90°F)
- The supply water pressure is between 100kPa (1 BAR) and 500kPa (5 BAR)
- The hardness of the water is less than 20°f (11.2°d)
- The conductivity of the water is not less than 10µs /cm at 25°C ambient temperature
- Installation of a water treatment system is recommended. Any solid elements (e.g. sand) can be removed by installing a mechanical filter that must be periodically inspected and cleaned. These filters must comply with/meet applicable national standards.

Each machine is supplied with water inlet hoses with a 3/4” connection which must be connected to the mains water supply. Replace any existing hoses and/or pipe fittings with a new set of hoses and gaskets.

- Attach the supplied drain pipe to the drain pipe fitting on the back of the ice maker.

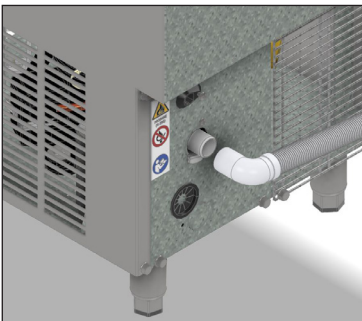

Connect the corrugated hose to the premise’s main drain. We recommend inserting a trap with siphon. If the ice maker is not fitted with a drain pump, the trap should be on the floor and the drain pipe should be laid well spread to avoid bottlenecks and promote proper drainage of wastewater. If the ice maker is fitted with a drain pump, the maximum drainage height is 600mm.

H.6 Electrical connection

Make sure the equipment is connected to an efficient earthing system and that the line voltage matches that specified on the machine's data plate.

 The electrical connection must be carried out by a qualified electrician, in compliance with the regulations in force.

 *To connect directly to the power supply, it is necessary to include an omnipolar switch which ensures disconnection from the power supply, with an aperture between the contacts to allow full disconnection in the conditions of a category III overvoltage, in compliance with installation regulations.*

Make sure the power cable was not damaged or crushed during handling.

 *If you should find a damaged power cable, it is strictly prohibited to connect and operate the ice maker. Have a qualified electrician replace the power cable with another cable whose characteristics comply with the standards in force in the country of installation.*

 *Do not plug the power cable in before completing installation and fitting the cover panels.*
Do not use multiple sockets or portable power supplies behind the appliance.

H.7 Safety devices installed

The machine has some devices that allow safe use.

1. The motor is equipped with an internal thermal protection.
2. The compressor is equipped with thermal protection.
3. The condenser temperature is monitored by a temperature probe that stops operation in case of abnormal temperature.
4. A temperature probe monitors the amount of ice present in the bin and stops operation of the ice maker when the bin is full of ice cubes.
5. A float switch checks for water in the tank and stops operation of the ice maker if there is no water.
6. Modular ice makers feature a safety switch that stops operation if the ice outlet chute becomes clogged with ice.

 The manufacturer declines any liability for damage or injury resulting from tampering with or non-use of these devices or due to non-compliance with the above instructions and the electrical safety regulations in force in the country of installation.

H.8 Positioning the modular ice maker

Modular ice makers are designed to be placed on top of the corresponding "Ice Bin" model, called STORE. Installation must be carried out only by professionally qualified personnel licensed for the task.

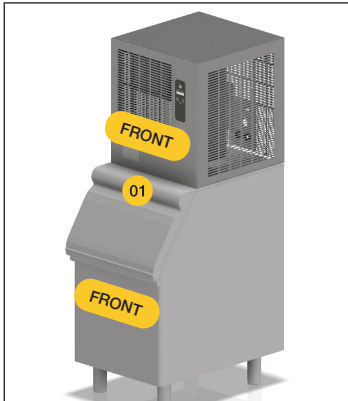

For handling and installation, we recommend using appropriate protective gloves and appropriate lifting devices according to weight.

Level the **STORE** by adjusting the feet and check with a spirit level that the **STORE** is perfectly level.

Place the modular ice maker on top of the **STORE** making sure to align the front of the ice maker with the front of the **STORE**, and to match the ice cube outlet with the store inlet hole (01).

Make sure the ice maker rests evenly.

Fasten the ice maker to the store with the screws provided.

H.8.1 Installing the ice level probe

After placing the ice maker on the STORE, it will be necessary to install the ice level probe.

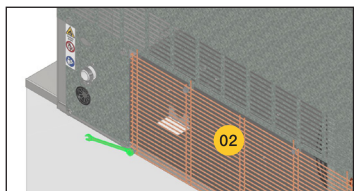

⚠ ⚠ Installation of the probe involves opening the technical compartment of the ice maker. Make sure that the machine is disconnected from the power supply. This operation should only be performed by an authorized technician.

- Open the rear ventilation grill (02).

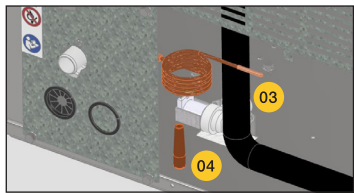

- Locate the level probe (03).
- Insert it into the appropriate seat (04) by lowering it to the bottom of the hose.
- Close the rear grill.

H.8.2 Connecting the modular ice maker

The electrical and plumbing connection does not change with respect to the free-standing ice maker. However, it is necessary to prepare a drain for the store as well.

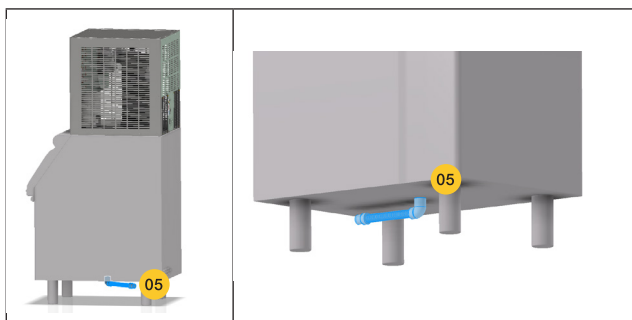

- Connect the corrugated hose (05) to the premise's main drain. We recommend inserting a floor trap with siphon that can accommodate both drain pipes. The **STORE** drain pipe should be laid well spread to avoid bottlenecks and promote proper drainage of wastewater.

H.8.3 Description of the modular ice maker

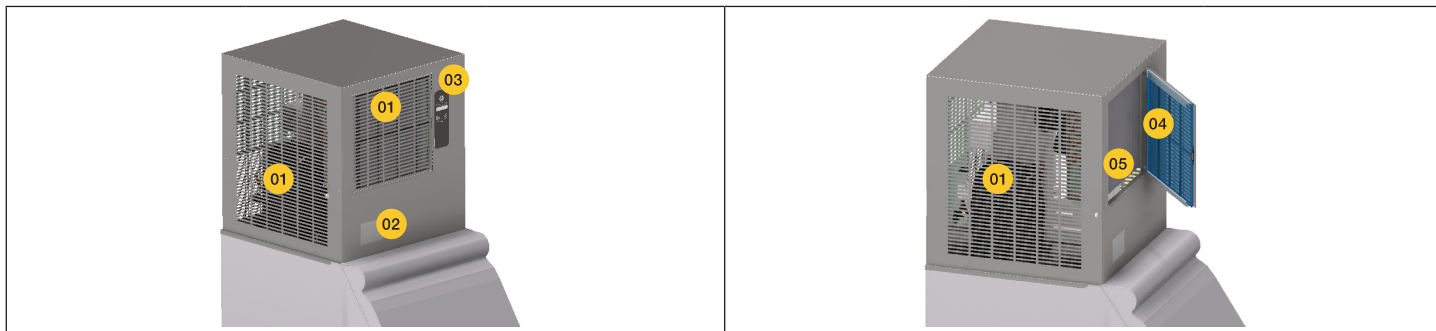

01	Ventilation grill
02	Data plate
03	Control panel
04	Air filter (air-cooled ice makers only)
05	Condensing unit (air-cooled ice makers only)

H.8.4 Connecting the modular ice maker

It is possible to stack 2 modular units and double productivity.

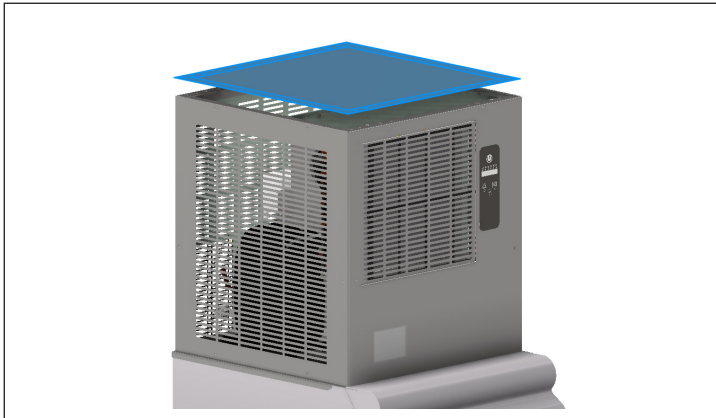

After placing and fastening the first modular ice maker onto the STORE, remove the top panel.

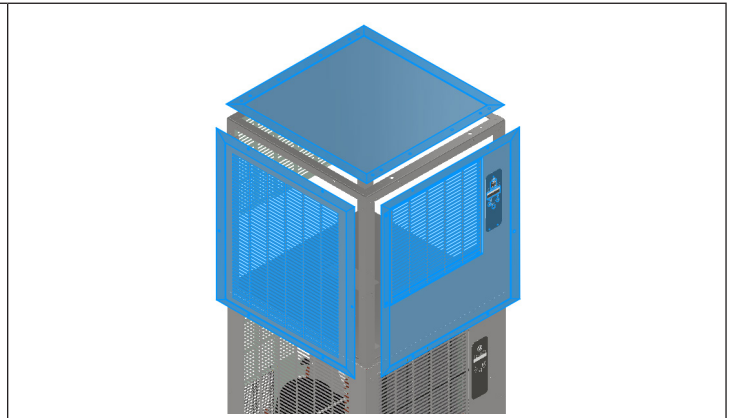

Place the second ice maker in position and remove the side panels.

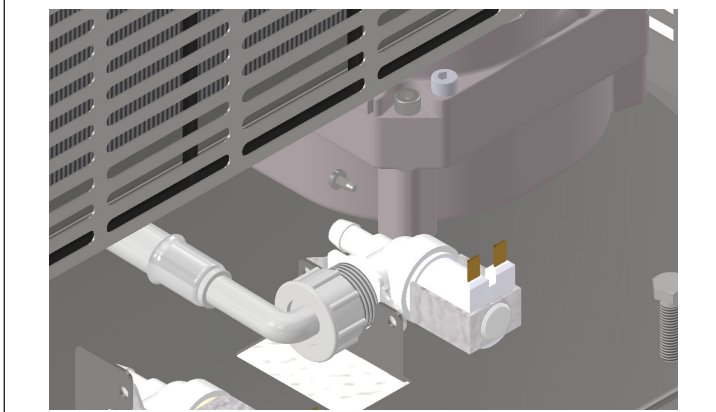



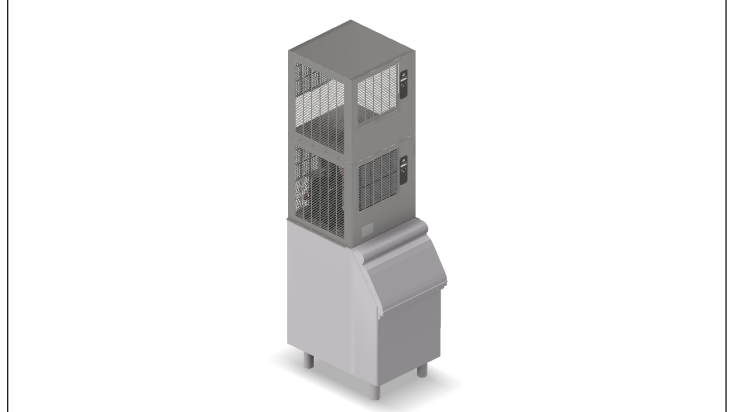







Use the screws provided to fasten the ice makers together.







Reattach all the side panels.

I DESCRIPTION OF CONTROLS

Control panel	Icon	Description
		On / Off button
		Voltage presence LED (<i>machine connected to power mains</i>)
		Cooling circuit in operation
		Fault (<i>see section on warnings and alarms</i>)
		Extraordinary maintenance required
		Active Wi-Fi connection (<i>requires Wi-Fi module option</i>)
		A schedule for turning the appliance on and off has been set
		Display
		USER MENU Button to set cube size and ice level in bin Negative adjustment button in menu
		USER AND SERVICE MENU Multifunction button to access menu Positive adjustment button in menu
ESC	Exit menu	

I.1 Color codes of the ON/OFF button

	FLASHING YELLOW: active warning		RED: alarm FLASHING RED: bypassable alarm
	GREEN: bin full		WHITE: in menu FLASHING WHITE: TEST-IN / OUT menu active exit
	BLUE: ice cube production in progress FLASHING BLUE: water tank fill in progress		

J START-UP

J.1 Start-up

The user must have sufficient knowledge and experience in order to read and understand the information in this manual, interpret the signs and symbols on the machine, and carry out safety operations (e.g. turn off the main switch if water leaks are detected or in case of malfunction causing unusual noises).

J.2 Preliminary checks and interior cleaning

Before operating the machine, make sure that there are no objects inside the bin.

Disconnect the ice maker from the power mains and thoroughly clean the interior, using a sponge moistened with lukewarm water mixed with a little baking soda, then rinse with pure water and dry thoroughly.

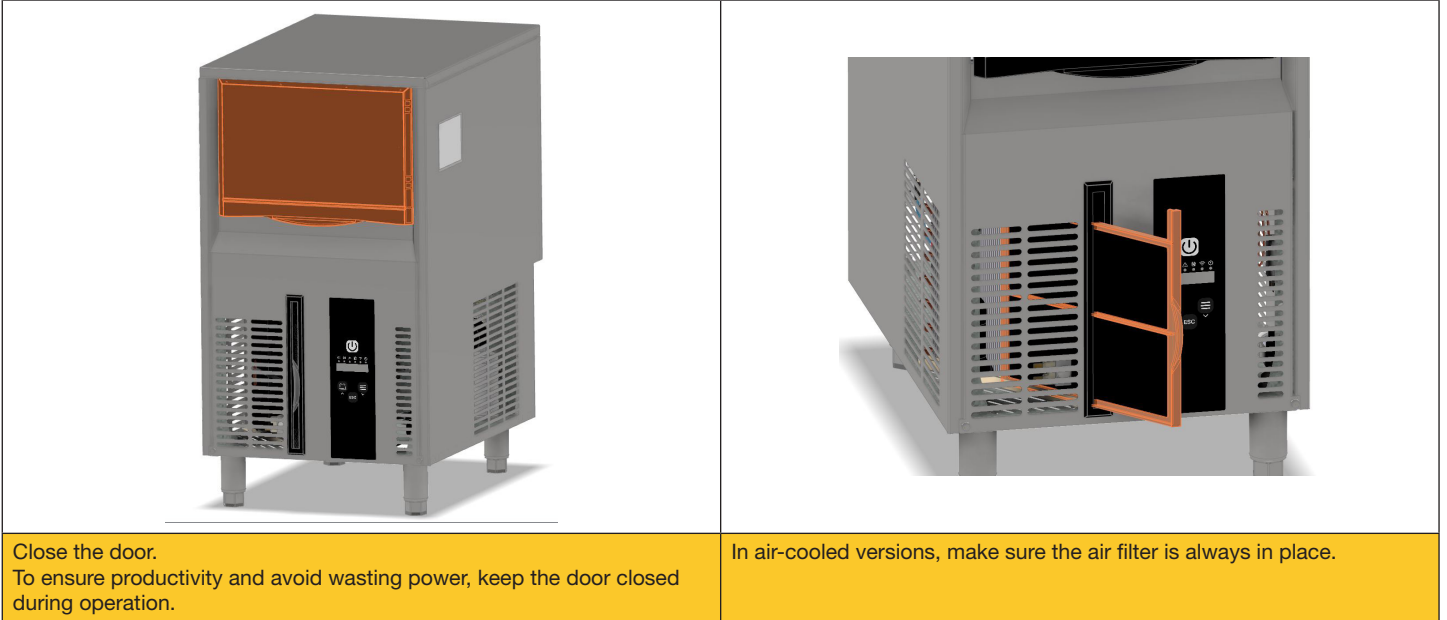

After running all above-listed checks:

- Make sure the power cable is connected to the control panel.
- Make sure the drain pipe is correctly inserted and on a slope into the drain trap.
- Make sure the inlet pipes/s is/are correctly installed and the water tap is open.



IMPORTANT: before switching on the machine, make sure the water tap is open. Starting the ice maker without water generates **ALARM 05**.

In water-cooled versions, lack of water will overheat the condenser, generating **ALARM 13**, which may only be reset by a specialized technician.

J.3 First switch-on

Press the ON/OFF (⏻) button to switch on the machine. The display shows a welcome message, after which the ice maker begins the initial startup phase, which lasts about 5 minutes.

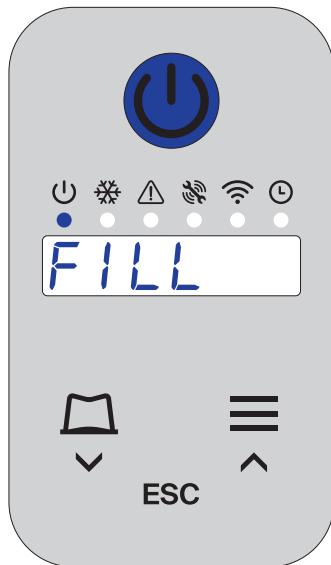

Once the machine has been switched on, the filling will start.

During the water filling process, the display will show the message "FILL" and the ON/OFF button will flash blue.



Once filling is complete, the ice maker will start making ice. Production is on a continuous cycle, until the bin is full.

During this stage, the display will show the message "ICE".

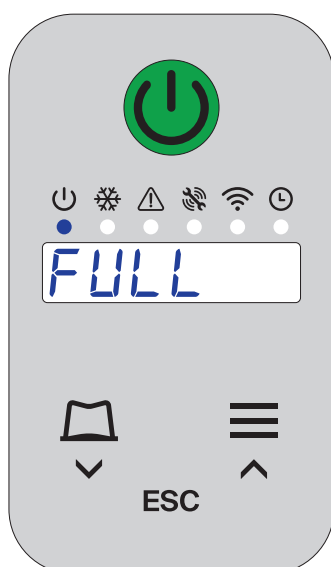

The ice cube production cycle stops as soon as the bin is full. This level is established by the "LEV" setting, which can be modified in the menu with the ICE CUBE icon (see *SETTINGS* section).

The production cycle restarts automatically when ice is collected.

Remove any ice chips that have gathered on the probe, so that production resumes faster (see steel tube inside bin).

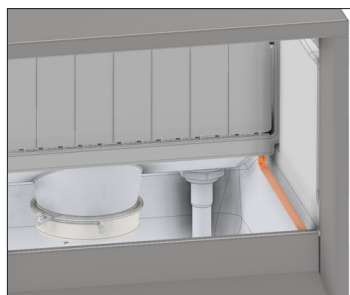

! Upon initial installation, we recommend discarding any ice made during the first hour of operation.

J.4 Turning off and turning on afterwards

Press the ON/OFF  button to switch off the machine.



- A “STOP” phase begins, lasting approximately 10 minutes. During this phase, the ice maker continues to make ice until all the water inside the evaporator has been completely drained.
- During this stage, the display will show the message “STOP”.
- A countdown is shown during the last 60 seconds.
- As soon as the ice maker turns off, the display shows the message “OFF”, which remains visible for 10 minutes; then the ice maker enters energy-saving mode, turning off the display.
- Only the voltage present indicator light will remain lit.



IMPORTANT

Before disconnecting power to the ice maker, we recommend turning it off by pressing the ON/OFF  button and waiting for the emptying operation to complete.

To avoid damage to the printed circuit board and the mechanical parts of the evaporator, do not unplug the unit or lower the upstream protective device without first turning off the ice maker.

K ADJUSTMENTS

K.1 Adjustments



There are 2 menus for setting operation of the ice maker:

Press the  button to access the **USER** menu.

Press the  button to access the **USER/SERVICE** menu.

Inside the menus, use the   arrow keys to scroll through the menu items.

Press the ON/OFF  button to edit the displayed menu item.

Use the   arrow keys to change the displayed value.

Save any changes by pressing the ON/OFF  button.

Press button **ESC** to quit the menu.



K.2 User menu and clock settings

In the **USER** menu, you can adjust the ice level in the bin, set the clock, and schedule on/off times.

You can access the menu even while the machine is running. The menu includes the following options:

- **LEV**: For setting the ice level in the bin. You can choose between **MAX** (maximum level) so that it fills to the level of the bin probe, or **MIN** (eco level) which amounts to about 30% less than the maximum level.

 The ice maker adjusts the quantity of ice in the bin depending on ambient temperature. To enable the bin probe to work properly, we recommend always keeping the door closed.

- **CK**: clock. Press the ON/OFF  button to enter edit mode and use the arrow keys to set the time.
- **ON**: power-on time. Press the ON/OFF  button to enter edit mode and use the arrow keys to set the power-on time for the entire week. The **OFF** setting cancels the scheduled power-on time.
- **OF**: power-off time. Press the ON/OFF  button to enter edit mode and use the arrow keys to set the power-off time for the entire week. The **OFF** setting cancels the scheduled power-off time.

K.3 User and service menu

In the **USER/SERVICE** menu, you can choose between:

- **SERVICE**: menu intended for installation technicians to set the operating parameters of the ice maker. Password-protected menu.
- **USER**: user menu containing the same options as the previous menu.

L CARE AND MAINTENANCE

L.1 Care and maintenance

Cleaning and maintenance must be carried out by the owner and/or the user of the ice maker at least once a month. In order to reduce the environmental impact of pollutants, we recommend cleaning the appliance with products which are at least 90% biodegradable. Any limescale can be removed by using a little vinegar.

L.2 Cleaning the tub

Clean the interior parts with a sponge dampened with lukewarm water mixed with baking soda. Rinse with pure water and dry thoroughly.

 We recommend avoiding using abrasive sponges or metal scouring pads as they can permanently damage the well.

L.3 Cleaning the external parts

Clean external parts only with products specifically designed for cleaning stainless steel.

Do not use corrosive products such as sodium hypochlorite or acids.

Do not clean the appliance with direct or high pressure jets of water.

Always keep the ventilation slots clean by vacuuming up any dust accumulation.

When cleaning the display, we recommend not using metal objects that can scratch the protective membrane or harsh detergents. Just wipe with a soft cloth moistened with a little water.

L.4 Cleaning the air filter

Air-cooled ice makers are equipped with a dust filter to protect the condenser. To maintain the ice maker's efficiency over time, we recommend periodically cleaning the filter by vacuuming out accumulated dust or washing it under running water.

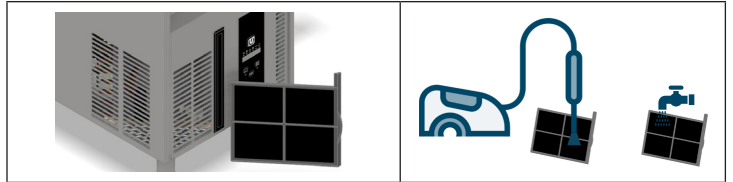

After 700 hours of operation, a FILTER message will appear on the display indicating that it is time to clean the filter. This message appears every 30 seconds and is reset by turning the machine off and on again.



- Do not wash the filter with detergent.
- Do not install the filter on the machine while it is still wet.
- Do not operate the machine without a filter.
- Do not operate the machine with a clogged filter.

L.5 Sanitization

At least once a year, we recommend having a specialized technician sanitize the system.

 After sanitization, discard any ice made during the first hour of operation.

L.6 Extraordinary maintenance

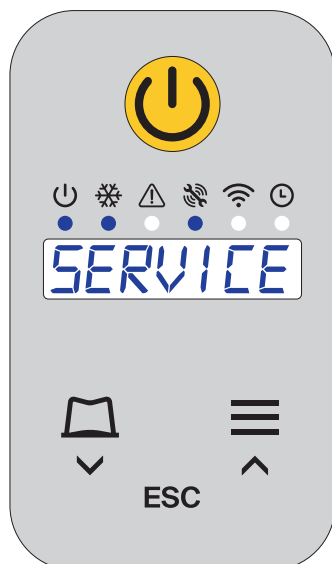

At fixed intervals depending on hours of operation, the **SERVICE REQUIRED** message will appear on the display and the maintenance wrench light  will come on, indicating that it is time to perform a general check of the internal components.

You can continue using the ice maker, but we recommend that you contact your authorized service center as soon as possible for the necessary checks.

M MAINTENANCE AND DISPOSAL TABLE

M.1 Maintenance and disposal

To ensure the appliance continues to be in good working order, we recommend carrying out the checks respecting the frequency indicated in the following table:

Maintenance, inspection and cleaning	Frequency	Person responsible
Cleaning and sanitizing the ice bin	Monthly	User
Cleaning the air filter (air-cooled versions only)	Every 700 hours of use	User
Sanitizing the evaporator and water tank	Yearly	Service
Cleaning the condenser (air-cooled versions)	Yearly	Service
Cleaning the solenoid valve filter	Yearly	Service
Checking integrity of power cable and inlet/outlet hoses	Yearly	Service
Checking proper operation of electrical parts, and checking condition of electric wires	Yearly	Service

M.2 When not in use

If the appliance is not going to be used for some time, take the following precautions:

- Turn off the water supply tap/s;
- Disconnect the power supply or remove the plug from the power socket;
- Empty the bin completely;
- Thoroughly clean the internal parts of the appliance;
- Clean the ice maker by vigorously wiping the exterior stainless steel surfaces with a cloth lightly soaked with paraffin oil to create a protective film;
- Clean the air filter, if present.

M.3 Appliance disposal

At the end of the product's life-cycle, make sure it is not dispersed in the environment. Dismantling of the appliance must be done in compliance with the regulations in force in the country of use.



The symbol on the product indicates that this item should not be treated as domestic waste but must be correctly disposed of in order to prevent potentially harmful consequences to the environment and to human health. For information about the recycling of this product, please contact your sales agent or dealer, your Customer Care Service, or your local waste disposal service.

Symptom	Type of problem	Possible causes	Corrective actions
The ice maker does not turn on	Impeding performance	The machine is not connected to the power supply	Check that the ice maker plug is plugged in. Check that the circuit breaker for the power cable is on
The bin is too full	Loss of performance	The ice maker is operating with the door open	Always keep the door closed during operation

Symptom	Type of problem	Possible causes	Corrective actions
The motor reducer is not on and the display is showing Alarm 12	Impeding performance	The motor reducer is blocked or the printed circuit board is not working	Contact technical assistance
The water-cooled ice maker is not filling with water and the display is showing Alarm 13	Impeding performance	Closed water tap or solenoid valve not working	Contact technical assistance
The ice bin is filling with water	Loss of performance	Pinched, crushed or incorrectly installed drain pipe	Fix the drain pipe
		Drain pump (where applicable) not working	Contact technical assistance

N WARNING

N.1 Display warnings

Warning messages may appear on the display if conditions occur which could compromise the proper operation of the ice maker.

No warning stops production of ice; however, resolve any warning as soon as possible to ensure the ice maker is always working correctly, avoiding loss in performance and increase in power and water consumption. The warnings are reported by means of the **ON/OFF** button flashing yellow and the message on the display:

Warning	Cause	Cure	View
FILTER	The condenser filter must be cleaned. Warning only appears in air-cooled ice makers.	As soon as possible, turn off the ice maker, remove and clean the filter, then turn on the ice maker again	Scrolling FILTER message
SERVICE	The threshold of operating hours for which scheduled maintenance is required has been reached.	Contact technical assistance to have scheduled maintenance performed and reset the partial cycle counter to zero	Scrolling SERVICE REQUIRED message In addition, the warning light  switches on



O ALARMS

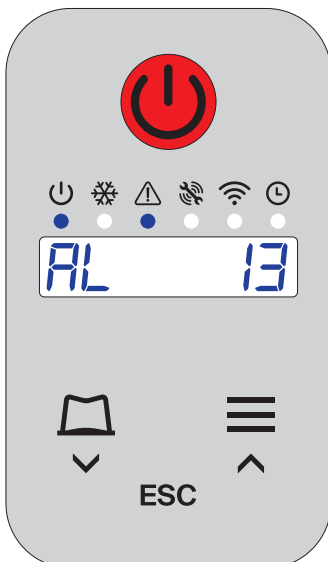

O.1 Display alarms



An alarm may occur when a component is malfunctioning, or due to incorrect operation by the user (e.g. failure to clean periodically or water shut off).

Some alarms stop the machine completely until the problem is resolved while other alarms can be bypassed by operating the ice maker with reduced functionality.

Alarm signals are indicated on the display with the letters AL followed by an error code; if the alarm is blocking the machine, the **ON/OFF**  button turns solid red, whereas if the alarm can be bypassed, the **ON/OFF**  button will be flashing red.

To bypass an alarm, press and hold the **ON/OFF**  button for 5 seconds. The display will read "ALARM BYPASS". From this moment on, the ice maker will operate in a limited function mode until the problem is rectified. A bypassed alarm makes the LED  light up.

To cancel the bypass, turn the ice maker off and on again.

O.2 Table of alarms

Alarm	Cause	User checks
AL01 (bypassable)	Ambient temperature outside operating range. The environment is too cold or too hot for the ice maker to operate correctly.	The alarm can be bypassed, but we recommend checking: -possibly inadequate recess (poor air circulation) -clean ventilation filter and grills -improve ventilation of premises -if the temperature is too low (<10°C), heat up the premises to prevent the components freezing.
AL02 (impeding performance)	Evaporator cooling failure.	Request technical assistance: possible gas leak from system.
AL03 (bypassable)	Failure to reach temperature for ice making. During the cooling phase, the evaporator temperature did not reach the value set within the scheduled time.	Keep the door closed during operation of the ice maker. The alarm can be bypassed, but if the problem persists, contact technical assistance.
AL05 (impeding performance)	Failure to fill water tank.	Check that the water tap is open and that the water inlet hose is not pinched. Turn the ice maker off and on again. If the problem persists, contact technical assistance.
AL06 (impeding performance)	No water. During normal operation, the water tank emptied.	Check that the water tap is open and that the water inlet hose is not pinched. Turn the ice maker off and on again. If the problem persists, contact technical assistance.
AL07 (impeding performance)	Drain time-out (only for ice makers with drain pump). The drain pump did not empty the water tank.	Check that the drain pipe is correctly positioned; if the problem persists, contact technical assistance.
AL08 (bypassable)	Bin probe temperature outside range.	Request technical assistance. The alarm can be bypassed by not checking the ice cube quantity in bin. After bypass, the ice maker will work for 3 hours. At the end of the 3 hours, operation will stop, and the display will show FULL. CAUTION: MONITOR THE AMOUNT OF ICE IN THE BIN.
AL09 (bypassable)	Evaporator probe temperature outside range.	Request technical assistance. The alarm can be bypassed by not checking the evaporator temperature. The ice maker will run on a timer.
AL10 (impeding performance)	Condenser probe temperature outside range.	Request technical assistance. The condenser temperature probe may be damaged.
AL 11 (bypassable)	Ambient probe temperature outside range.	Request technical assistance. The alarm can be bypassed by not checking the ambient temperature. The quantity of ice with the bin FULL may be different with respect to normal operation.
AL 12 (impeding performance)	Evaporator temperature too low.	Ambient temperature too low or evaporator probe is faulty. Turn off the ice maker and wait 10 minutes before turning it on again. If the problem persists, contact technical assistance.
AL 13 (impeding performance)	The condenser temperature has reached 70°C and the safety probe has blocked operation of the ice maker.	Request technical assistance. -possibly inadequate recess (poor air circulation) -clean ventilation filter and grills -improve ventilation of premises -in the case of water-cooled appliances, check that the water tap is open and that the water inlet hose is not pinched. Reset can only be performed by an authorized technician.
AL 14 (impeding performance)	Thermal protection tripped for motor reducer.	Turn off the ice maker and wait 10 minutes before turning it on again. If the problem persists, contact technical assistance.
AL 15 (impeding performance)	Safety micro-switch tripped for evaporator (modular models only).	The ice outlet chute is full. Empty it, turn the ice maker off and on again.

ALARM RESET: By turning the ice maker off and back on again, all alarms will be reset, except for Alarm 13, which can only be reset by an authorized service center.



This bypass should only be understood to be a temporary emergency operation, and not normal operation. We recommend requesting an authorized technician as soon as possible to eliminate the cause that generated the alarm.

O.3 Power blackout

In the event of a power blackout, after power is restored, the ice maker will resume normal operation.

CE